

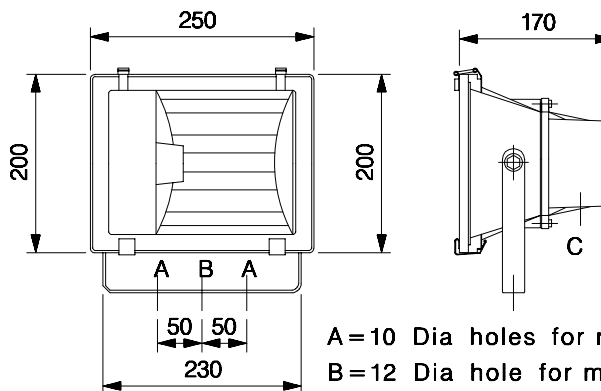

AREA LIGHTING

BGEMFS 150 MH SE

Asymmetrical beam, integral, compact floodlight luminaire for HID lamp



A = 10 Dia holes for mtg.-2 Nos
 B = 12 Dia hole for mtg.-1 No.
 C = Cable entry-1 No.

Nominal dimensions in mm Tolerance +/-5 (Except mtg. Hole)

Applications

- Pedestrian crossings
- Walkways and pathways
- Building & monuments
- Hoardings and sign boards
- Security lighting, etc.

Specification

- Epoxy black powder coated, die-cast aluminium housing with control gear accessories for 150 MH SE lamp in the rear side
- Electrochemically brightened, polished, faceted **GLASKOTE™** aluminium reflector
- Heat resistant, clear toughened glass cover in the front with hinged and silicon rubber gasket
- E-27 lamp holders prewired upto the terminal block
- Epoxy black powder coated MS mounting bracket, graduated aiming disc and locking facility at any angle in the vertical plane
- Degree of protection : IP 55

Electrical Data

| Cat. Ref. | Lamp Type & Wattage (W) | Nominal Voltage (V) | Mains Current in Amps. at 240 V | Capacitor Mfd. | Power Factor |
|------------------|-------------------------|---------------------|---------------------------------|----------------|--------------|
| BGEMFS 150 MH SE | MH SE 150 | 220/240 | 0.80 | 20 | ≥ 0.85 |

Data subject to variation due to change/improvement in the design, materials and processes.

| | | | | |
|--|----------------------------|-----|------------|--|
| <p>BAJAJ LUMINAIRES Making the difference</p> | DRAWN | VDS | 04-01-2005 | FOR - std. |
| | CHECKED | KS | | REV - 0 DATE-10-01-2008 |
| | APPROVED | CRR | | DRG. No |
| | DATA SHEET RELEASED ON DT- | | | EMFS 150 MH SE-001 |
| <p>BAJAJ ELECTRICALS LIMITED 15/17, SANT SAVTA MARG, REAY ROAD, MUMBAI-400 010.</p> | | | | <p>* E-mail : luminaires@bajajelectricals.com</p> |