

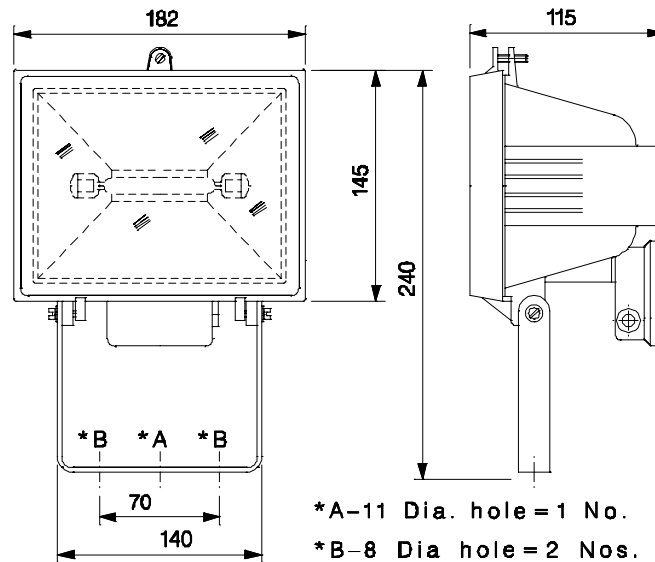

AREA LIGHTING

BAJAJ BJQF 500



NOMINAL DIMENSIONS IN mm Tolerance +/-5 (Expect mtg. Hole)

Application

Halogen lamp floodlight luminaire is designed for illuminating Building facades, Sign boards, Sports fields and other general floodlighting application. Particularly suited where instant light, high colour rendition or low initial cost is important.

Specification

- Compact in design and light in weight this luminaire consists of a single piece pressure die-cast aluminium housing having heat radiating fins.
- High purity electrochemically brightened and polished aluminium reflector provides the optical control.
- Heat resistant toughened clear glass cover is fitted in hinged aluminium frame having rubber gasket to make the luminaire dust and weatherproof.
- Unique lamp holders with heat sink design suitable for double ended halogen lamp ensure long trouble free service, prewired with teflon wires upto mains connector block.
- The luminaire is provided with mounting bracket and can be fixed at any angle in the vertical plane.
- Relamping is from the front.
- Finish: Black powder coated.
- Degree of protection: IP 54

Electrical Data

Cat. Ref.	Lamp Type & Wattage (W)	Nominal Voltage (V)	Mains Current In Amps. At 240 V
BJQF 500	HALOGEN 500	240	2.10

Data subject to variation due to change/improvement in the design, materials and processes.

<p>BAJAJ LUMINAIRES Making the difference</p>	DRAWN	VDS	08.10-2004	FOR –
	CHECKED	DVRS		REV - 0 DATE-01-02-2008
	APPROVED	CRR		DRG. No
	DATA SHEET RELEASED ON DT-			QF 500 - 001
BAJAJ ELECTRICALS LIMITED 15/17, SANT SAVTA MARG, REAY ROAD, MUMBAI-400 010.				* E-mail : luminaires@bajajelectricals.com