

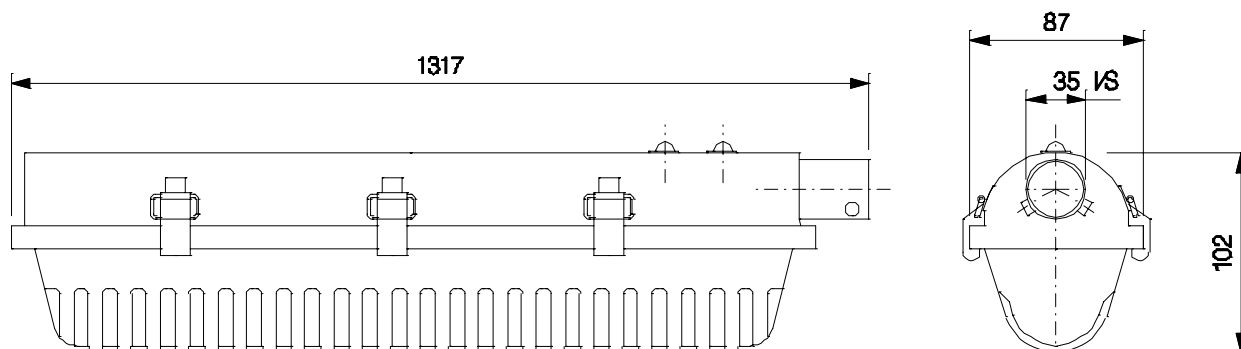

## ROADWAY LIGHTING

**BAJAJ** BJSLF 1140 MS

Fluorescent lamp luminaire for group B2 roadway installation



Dimensions in mm Tolerance +/-5

**Application**

- Medium traffic roads
- Security lighting
- Industrial complexes
- Residential colonies
- Service stations, etc.

**Specification**

- MS housing with munshell grey stove enamelled finish
- Stove enameled MS sheet steel reflector
- Highly transparent, ribbed acrylic bowl with rubber gasket fixed to the housing with toggle latches
- Wired with open construction ballasts suitable for single 36/40W FTL
- Side entry mounting for 20 to 30 mm OD pipe bracket
- Degree of protection : IP 43

**Electrical Data**

Cat. Ref.	Lamp Type & Wattage (W)	Nominal Voltage (V)	Mains Current in Amps. at 240 V	Capacitor Mfd.	Power Factor
BJSLF 1140 MS	FTL 1 x 40	230	0.19	4.00	0.90

Data subject to variation due to change/improvement in the design, materials and processes.

 <b>BAJAJ LUMINAIRES</b> <i>Making the difference</i>	DRAWN	VDS	07-10-2005	FOR – Std.
	CHECKED	DVRS		REV - 0 DATE-04-01-2008
	APPROVED	CRR		DRG. No
	DATA SHEET RELEASED ON DT-			<b>SLF 1140 MS - 001</b>
<b>BAJAJ ELECTRICALS LIMITED</b> 15/17, SANT SAVTA MARG, REAY ROAD, MUMBAI-400 010.				* E-mail : <a href="mailto:luminaires@bajajelectricals.com">luminaires@bajajelectricals.com</a>